

### Content:

|                                     |   |                                   |   |
|-------------------------------------|---|-----------------------------------|---|
| Technical specification and battery | 1 | Set automatic timer Remove / turn | 4 |
| Display, unlock and mode setting    | 2 | off timing position Programming   | 5 |
| Switching between 15 and 2 channels | 3 | Shuttle motors                    | 5 |
| Set time and day                    | 3 |                                   |   |

### TECHNICAL SPECIFICATION:

- 2x Alkaline battery type AAA, LR03
- battery life < 3 years
- frequency 433.92MHz
- transmit power max. 10mW
- transmit range indoor 98 feet
- working temperature 14°F - 122°F
- each channel can control up to 20 receivers

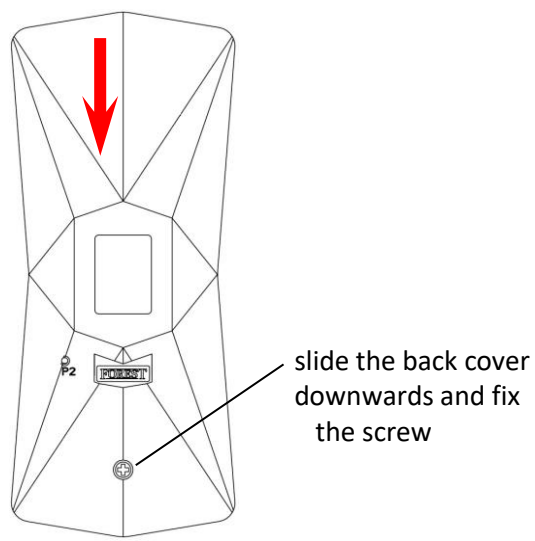
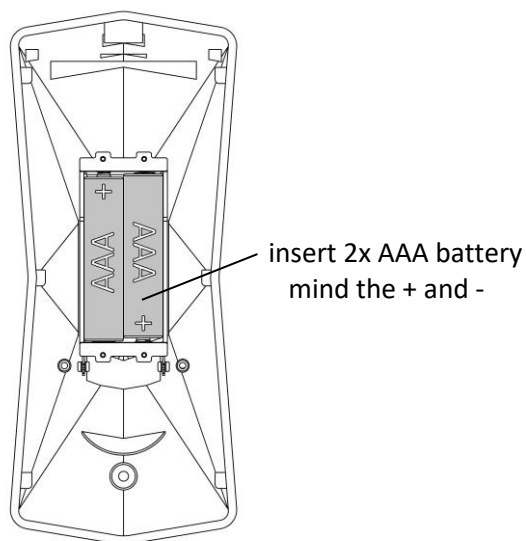
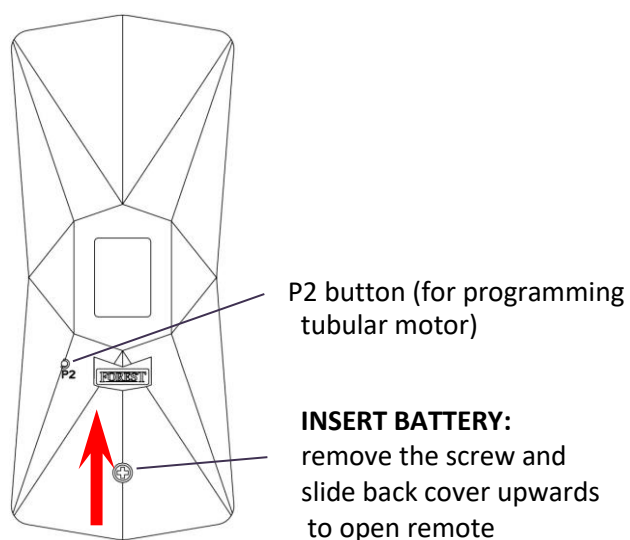
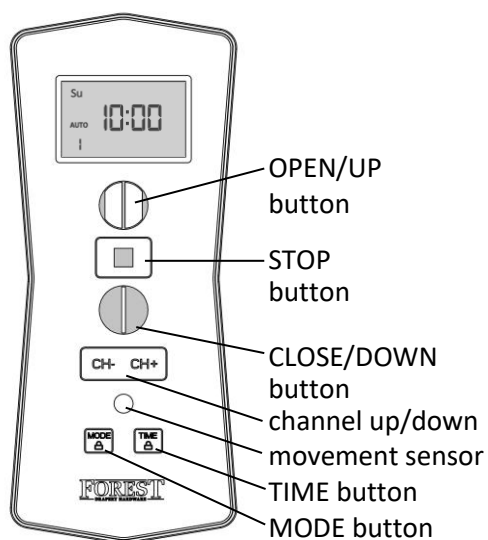

### BATTERY EMPTY:

After changing the battery, programmed receivers will stay in memory of Diamond Sense remote. Please follow the local regulations for disposal of the empty battery.

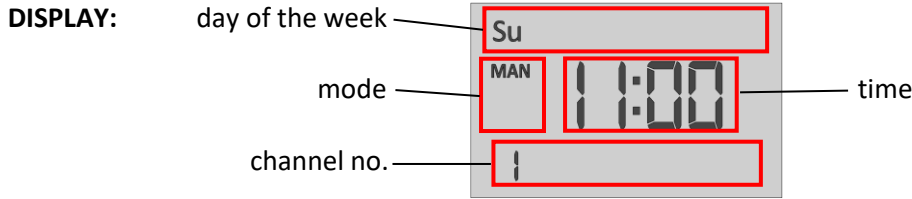

### UNLOCK THE MODE AND TIME BUTTONS:

Keep both buttons MODE and TIME pressed for about 4 seconds until the display shows 'LOC'. Now you can set the mode and time.

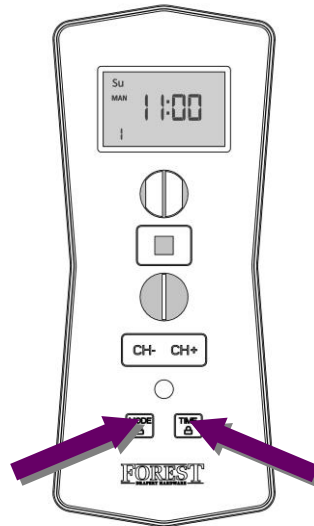

- MODE:**
- MAN ⇌ Manual mode: automatic timer mode is off
  - AUTO ⇌ Auto mode: automatic timer mode is on
  - AUTO ⇌ Random mode: automatic timer mode is on, OPEN and CLOSE time will vary between + and – 15 minutes

To change the mode, keep 'MODE' pressed until the desired mode appears in the display:

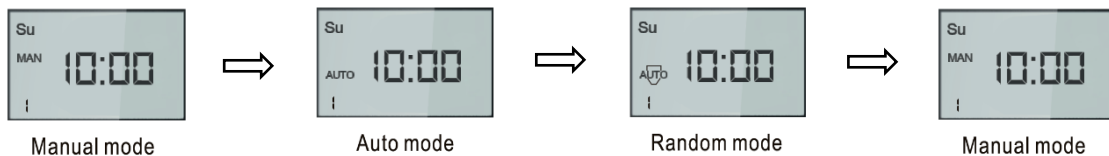

### SWITCHING BETWEEN 15 AND 2 CHANNELS:

Default setting of the Diamond Sense is 15 channels. Channel 1 up to 15 can be used. When desired, for example when you only have one or two motorized systems, you can change the setting to 2 channels:

Keep both buttons, CH- and CH+ pressed for about 8 sec until the display shows F-02. Now the Diamond Sense is a 2-channel remote control.

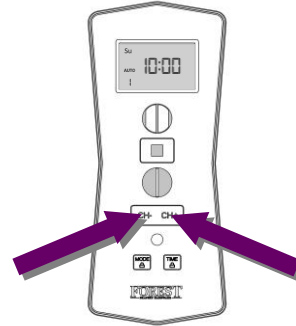

To change back to a 15-channel remote control: Keep both buttons, CH- and CH+ pressed for about 8 sec until the display shows F-15. Now the Diamond Sense is a 15-channel remote control.

### SET CURRENT TIME AND DAY (when necessary, first unlock the buttons: press and hold MODE and TIME):



MODE must be 'MAN'

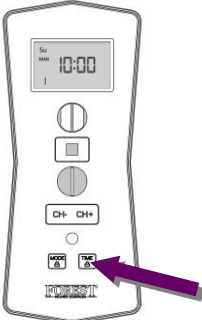

press TIME button once, hours start blinking

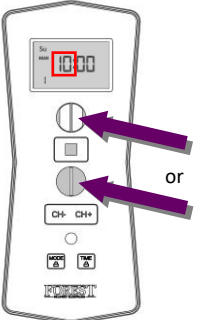

change hours by pressing OPEN or CLOSE button

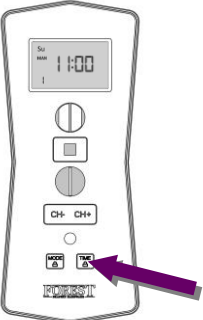

press TIME button once, minutes start blinking

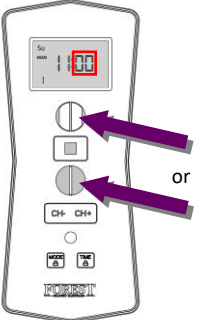

change minutes by pressing OPEN or CLOSE button

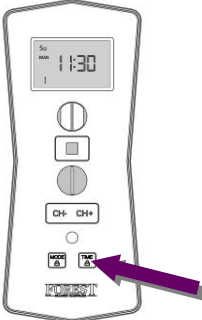

press TIME button once, day starts blinking

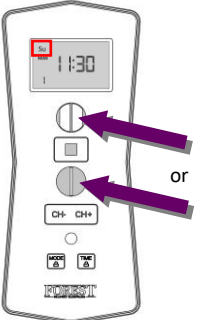

change day by pressing OPEN or CLOSE button

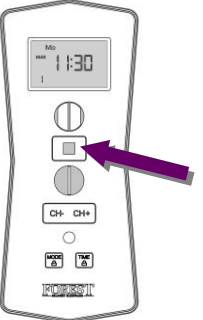

press STOP button to finish

### SET AUTOMATIC OPEN AND CLOSE TIME (first unlock the buttons: press and hold MODE and TIME):

In total up to 9 OPEN and 9 CLOSE timing positions can be set. For example use 4 points:

Position 1: Ma-Tu-We-Th-Fr ⇒ 7:30 OPEN

Position 2: Ma-Tu-We-Th-Fr ⇒ 21:00 CLOSE

Position 3: Sa-Su ⇒ 7:00 OPEN

Position 4: Sa-Su ⇒ 20:00 CLOSE

### SET TIMING POSITION 1 – OPEN:

MODE must be 'AUTO' or 'AUTO' (press and hold MODE button)

press MODE button once

select the desired channel

press TIME button once, hours start blinking

change hours by pressing OPEN or CLOSE button

press TIME button once, minutes starts blinking

change minutes by pressing OPEN or CLOSE button

press TIME button one, day starts blinking

change day(s) by pressing OPEN or CLOSE button

press STOP button to finish

### SET TIMING POSITION 1 – CLOSE:

Repeat steps here above, only start by pressing MODE button twice

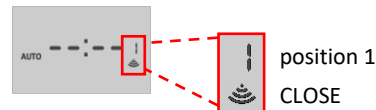

### NEXT TIMING POINTS:

can be set in the same way, press multiple times the MODE button until desired timing position OPEN or CLOSE is reached. Maximum of 9 OPEN and 9 CLOSE positions can be set.

**REMOVE / TURN OFF TIMING POSITION** (example shows timing position 1 OPEN now on 07:00 CH2 → turn off)

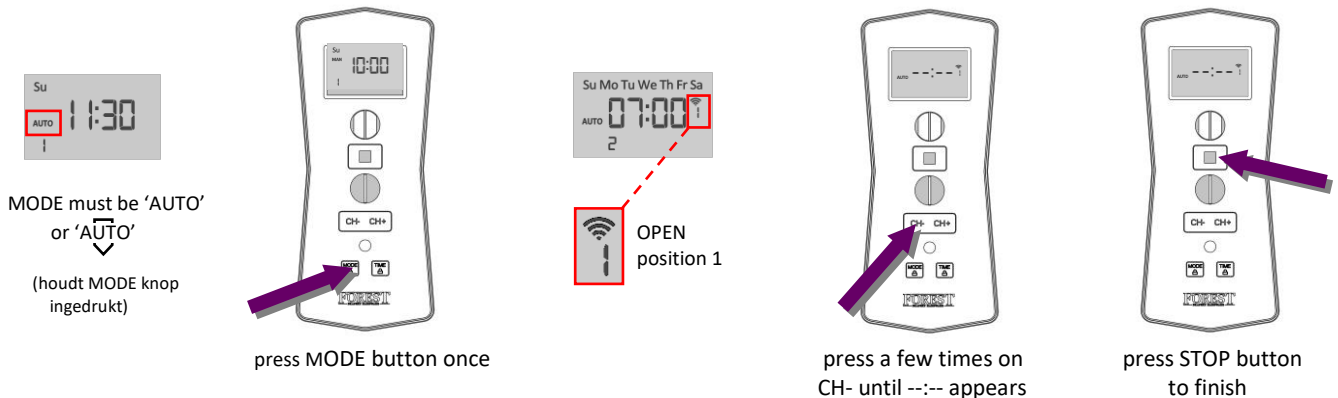

When desired, repeat this action for any other timing position.

To turn off all timers temporarily, set the remote control to mode 'MAN', see page 2.

## FOREST SHUTTLE HD/L/ECO RECEIVER PROGRAMMING

You can recognize these Shuttle motors by the white antenna cable.

To program a Diamond Sense to a Shuttle HD/L/ECO Receiver, first select the desired channel and proceed:

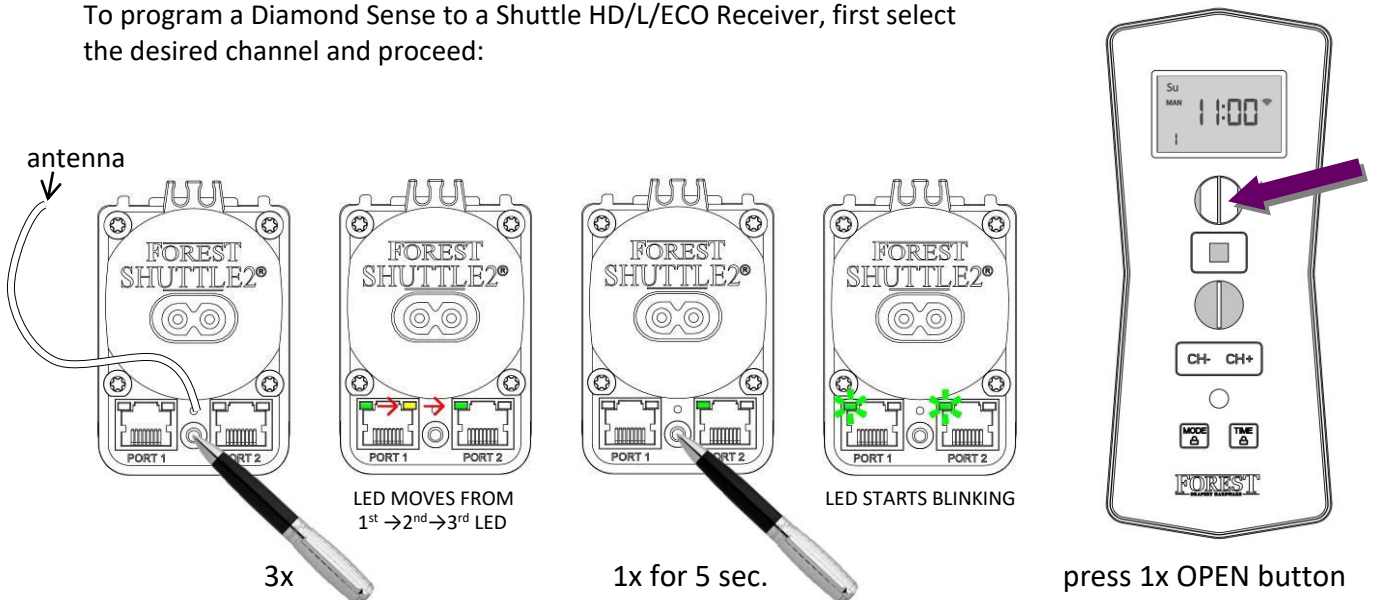

Same procedure, but press CLOSE instead of OPEN, will erase the programmed channel.



Do not mount the motor within 3 feet of other equipment and receivers. This will interfere with the receiver.

**FCC PART 15 CERTIFICATION**

This device complies with part 15 of the FCC Rules. Operation is subject to the following two conditions: (1) This device may not cause harmful interference, and (2) this device must accept any interference received, including interference that may cause undesired operation.