

RBS® ROMAN SHADES

RBS® Roman Shades set the standard with their ultra-slim profile and unmatched performance. When only the best will do, choose RBS®. Chain operated or motorized.

RBS® ROMAN SHADE SYSTEM
RBS® MOTORIZED ROMAN SHADE SYSTEM

THE WORLD
BEHIND
YOUR
DRAPERIES







25
White







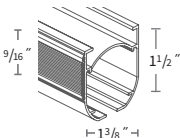
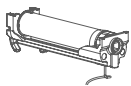
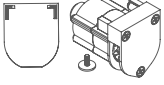
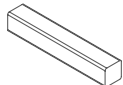
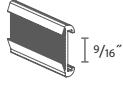

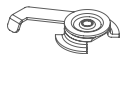
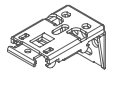
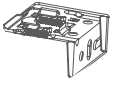
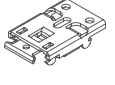
RBS ROMAN BLIND SYSTEM

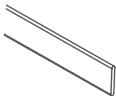
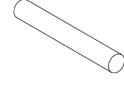
- The most durable and functional roman blind system on the market. RBS includes integrated Velcro tape so the fabric can be easily attached and removed.
- Aluminum, white, powder coated extrusion. Best suited for light to medium weight fabrics in contract or residential applications.
- Maximum weights:
 - 1:4 gear up to 18 lbs.
 - 1:2 gear up to 14 lbs.
 - 1:1 gear up to 10 lbs.
- Includes child safety device and warning label.

ASSEMBLED SYSTEM

Includes headrail with integrated Velcro tape, cord roll supports, wall or ceiling brackets, counterweight (if requested), chain, child safety tension device & warning label. When ordering, please specify chain drop length, wall or ceiling mount, control side, and number of cord roll supports needed.

RBS	COMPONENT
• 	41019-25 RBS Headrail with integrated Velcro tape 19' x 10 rails/bundle bundle = 190'
• 	49010-25 RBS Cord Roll Support w/ quick lock, 12' drop
• 	Control Unit w/ End Cap & Retaining Ring heavy duty, self-braking 42311-25 1:4 gear to 18 lbs. 42312-25 1:2 gear to 14 lbs. 42310-25 1:1 gear to 10 lbs.
• 	41119-90 19' Rod aluminum 3/16" x 3/16"
• 	31116-25 Velcro Profile w/Hook Tape, 13.1'
• 	39007-25 Velcro Tape 27 yds. per roll
• 	43202-25 Swivel Wall Bracket
• 	43003-25 Swivel Ceiling Bracket
• 	43033-25 Klick Wall Bracket
• 	43034-25 Hidden Klick Multi Bracket
• 	43004-25 Klick Ceiling Bracket

RBS	COMPONENT
• 	49005-25 Bottom weight, 19' aluminum 1" x 1/8"
• 	49006-25 Fiberglass Spines, 19' 3/16" diameter
• 	49008-25 Shade Leveler
• 	49014-25 Plastic Snap Ring
• 	49013-25 Plastic Ring Cord Guide
• 	Endless Chain 25 white plastic or 90 nickel 49020-25, 90, 29" drop 49021-25, 90, 39" drop 49022-25, 90, 49" drop 49023-25, 90, 59" drop 49024-25, 90, 69" drop 49025-25, 90, 79" drop 49026-25, 90, 89" drop 49027-25, 90, 99" drop
• 	76047-90 Metal Ball Chain Stopper
• 	79005-00 Clear Ball Chain Stopper
• 	49502-00 Tension Device for child safety

• Standard item in assembled sets.

RBS® CHAIN DRAW SPECIFICATIONS

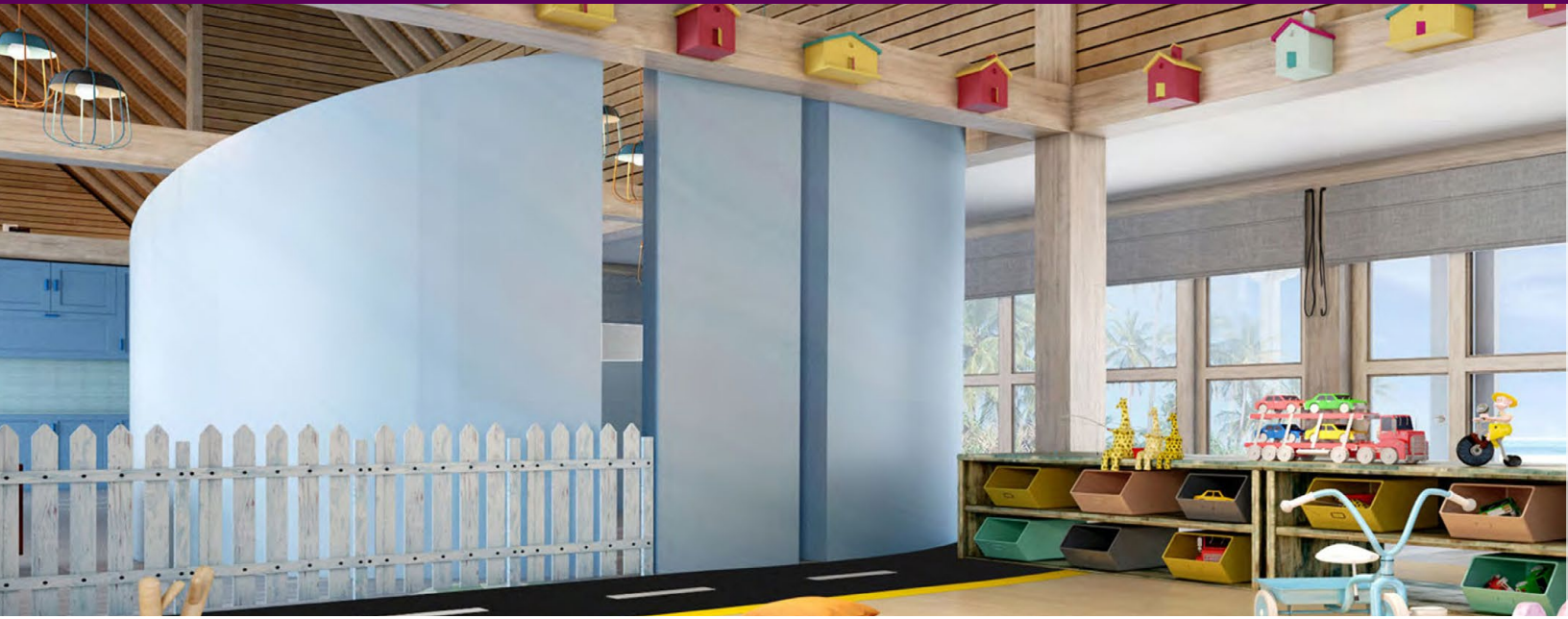

PRODUCT INFORMATION

- For all types of light and medium weight draperies.
- Elegant shaped aluminum profile with Velcro hook tape.
- Profile is aluminum with a chromated powder coated white finish.
- Maximum weights:
 - 1:4 gear up to 18 lbs.
 - 1:2 gear up to 14 lbs.
 - 1:1 gear up to 10 lbs.
- 10 year warranty.
- Corded system includes a child safety tension device and warning label.

CHILD SAFETY

All Forest corded products include a child safety tension device and a warning label.

PROFILE

- Aluminum extrusion 6063 T5
- Size 1 3/8" x 1 1/2"
- Finish available: white

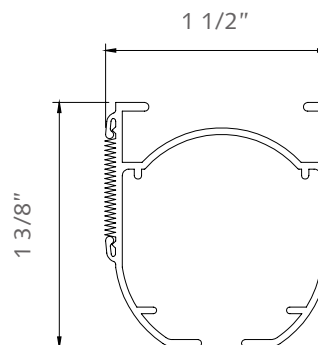

FOR USE IN

Hotels, offices, residences, schools, healthcare facilities, or at any location where an efficient roman blind system is desired.



RBS ROMAN BLIND SYSTEM

The Forest Roman Blind System - RBS® is the most widely used and recognized roman blind in the industry. It comes with integrated Velcro tape so the fabric can be easily attached & removed. The system is always correctly aligned due to the twist lock on the cord roll support. For the ultimate convenience, choose a motorized solution.

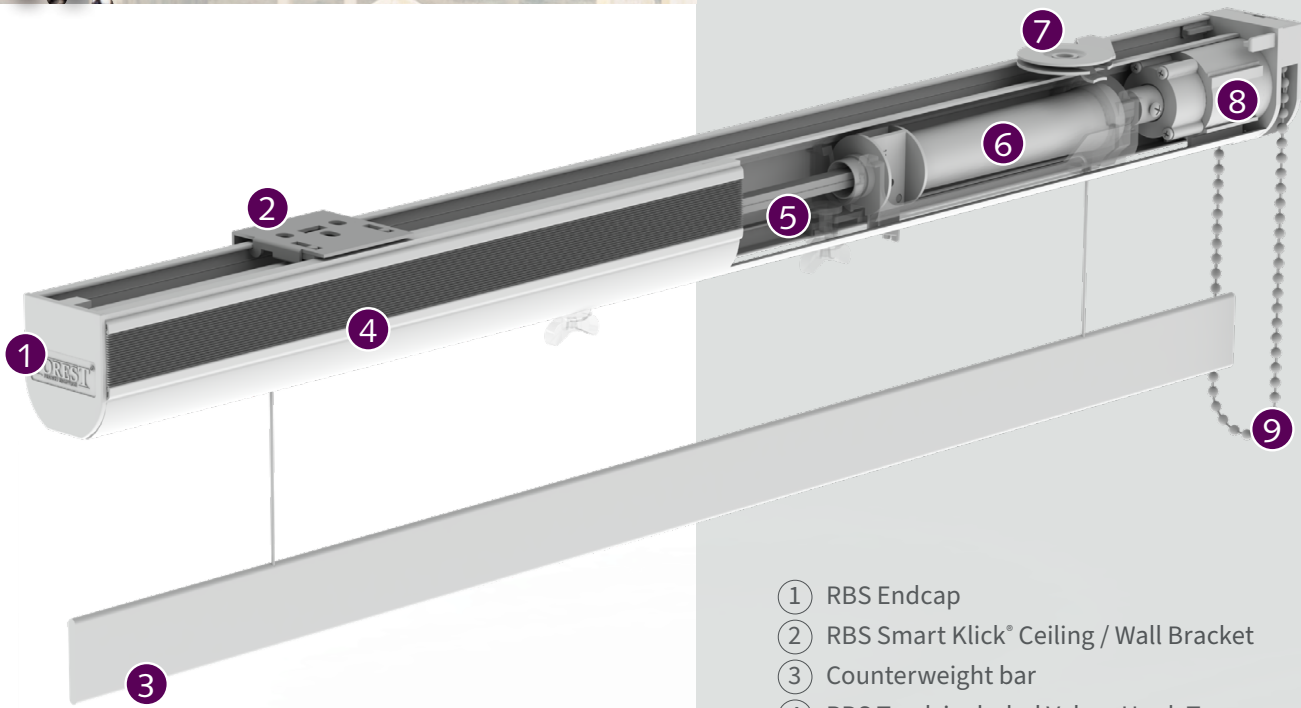

- ① RBS Endcap
- ② RBS Smart Klick® Ceiling / Wall Bracket
- ③ Counterweight bar
- ④ RBS Track included Velcro Hook Tape
- ⑤ RBS Rod 3/16" x 3/16"
- ⑥ RBS Quicklock Cord Roll, 12' drop
- ⑦ RBS Swivel Ceiling Bracket
- ⑧ RBS Control Unit 1:4
- ⑨ Chain
- ⑩ Child Safety Tension Device













25
White

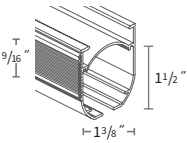
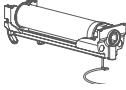

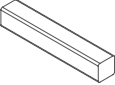

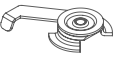
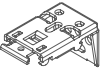
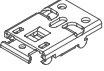
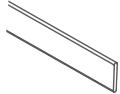

RBS MOTORIZED ROMAN BLIND SYSTEM

- The most durable and functional roman blind system on the market. RBS Motorized includes integrated Velcro tape so the fabric can be easily attached and removed.
- Aluminum, white, powder coated extrusion. Best suited for light weight fabrics in contract or residential applications.
- Maximum weight is 10 lbs with a maximum width of 84".
- The motor and lithium iOn battery each include a 1 year warranty. See all motor specifications on the following pages.

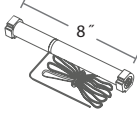
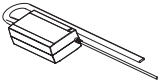
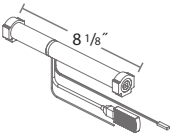
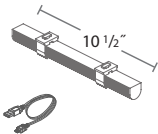
ASSEMBLED SYSTEM

Includes headrail with integrated Velcro tape, cord roll supports, brackets, counterweight (if requested), motor and EasyTouch remote. When ordering, please specify motor side, wall or ceiling mount, and number of cord roll supports needed.

RBS MOT	COMPONENT
	41019-25 RBS Headrail with integrated Velcro tape 19' x 10 rails/bundle bundle = 190'
	49010-25 RBS Cord Roll Support w/ quick lock, 12' drop
	62913-25 RBS End Caps left & right
	41119-90 19' Rod aluminum 3/16" x 3/16"
	43202-25 Swivel Wall Bracket
	43003-25 Swivel Ceiling Bracket
	43033-25 Klick Wall Bracket
	43034-25 Hidden Klick Multi Bracket
	43004-25 Klick Ceiling Bracket
	49005-25 Bottom weight, 19' aluminum 1" x 1/8"
	49006-25 Fiberglass Spines, 19' 3/16" diameter
	49008-25 Shade Leveler
	49014-25 Plastic Snap Ring
	49013-25 Plastic Ring Cord Guide

RBS MOT	COMPONENT
	62903-25 AC RBS Motor 24 V, double shaft, lifts up to 10 lbs. See motor specs on the follwong pages
	52928-25 7' 6" cord 52934-25 16' cord includes 24 V power supply for 62903-25
	52615-25 iOn RBS Motor 24 V, includes end caps, and Bluetooth module. See motor specs on the follwong pages
	52616-25 Lithium iOn Battery Pack includes mounting brackets and USB-C charging cable
	52960-25 white 52960-59 black EasyTouch Remote 6 channel hand held remote Optional holder below can be ordered separately
	52961-00 EasyTouch Remote Holder Optional and must be ordered separately
	52933-25 white 52933-59 black EasyTouch Wall Switch 2 channel
	52955-25 Bond Bridge Pro For voice and app control over RF. Easily pair using the Forest remote. Controls all of your devices in one hub.
	52954-25 Sidekick Gen 4 Remote Works with or without Bond Bridge Pro, 1-5 channels.

• Standard item in assembled sets.

RBS® MOTORIZED SPECIFICATIONS



PRODUCT INFORMATION

- Headrail finish: durable, high-quality aluminum with a powder-coated finish.
- Color available: white.
- Charging motor takes 6-8 hours or until the blue light comes on.
- 6 month battery life with one up & one down per day.
- 5 year warranty on motor.
- 2 Year warranty on the battery pack.
- Application width: minimum 20.87" and maximum 84".
- Available height: 138".
- Maximum fabric weight: 2 1/4 lbs per cord roll, or 10 lbs per system.

CONTROL OPTIONS



 bond

PROFILE

- Aluminum extrusion, 6063 T5
- Size 1 3/8" x 1 1/2"
- Color available: white

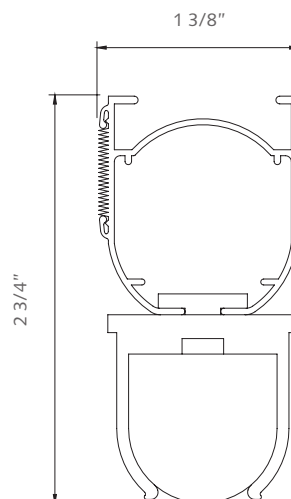

FOR USE IN

Hotels, offices, residences, boats or anywhere an efficient motorized Velcro track system for roman shades is required.

RBS MOTORIZED ROMAN BLIND SYSTEM

The Forest Roman Blind System - RBS® is the most widely used and recognized roman blind in the industry. It comes with integrated Velcro tape so the fabric can be easily attached & removed. The system is always correctly aligned due to the twist lock on the cord roll support. Operate RBS by remote, wall switch, or smartphone app.

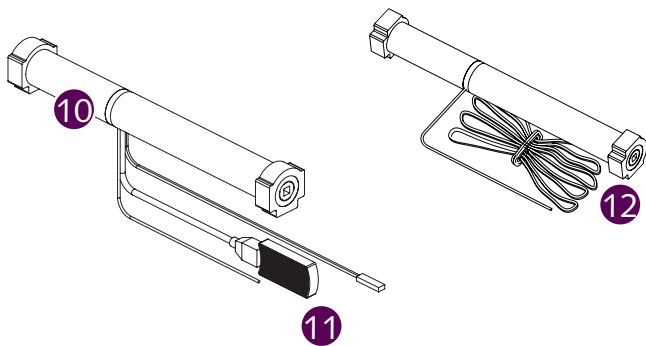
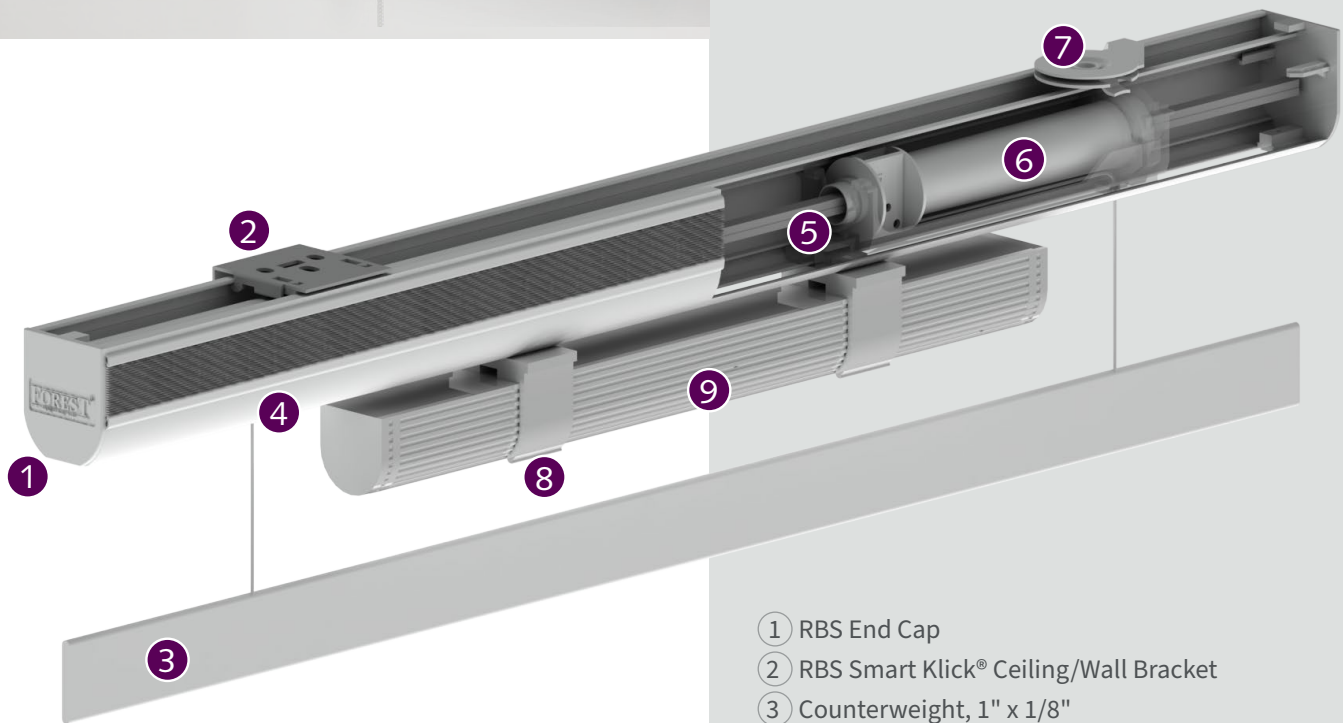

- ① RBS End Cap
- ② RBS Smart Klick® Ceiling/Wall Bracket
- ③ Counterweight, 1" x 1/8"
- ④ RBS Headrail with integrated Velcro tape
- ⑤ RBS Rod, 3/16" x 3/16"
- ⑥ RBS Cord Roll Support
- ⑦ RBS Swivel Ceiling Bracket
- ⑧ Battery Bracket
- ⑨ Lithium iOn Battery Pack, 10 1/2" x 1" x 1"
- ⑩ 52615 iOn RBS – Lithium iOn battery powered motor
- ⑪ Bluetooth module
- ⑫ 62903 AC RBS – a wired motor system is also available

FOREST TUBULAR MOTOR SPECIFICATIONS



68002 iOn

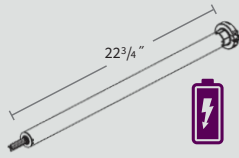

52615 iOn RBS

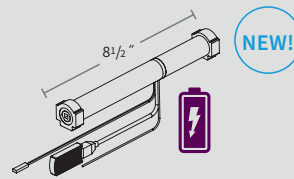

62903 AC RBS

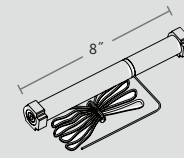

USE WITH

ENDEAVOR	√	-	-
RBS®	-	√	√
BCS	√	-	-

SPECIFICATIONS

TORQUE	1.8 Nm	0.8 Nm	0.8-1.0 Nm
POWER	12V + LiOn battery	12V 9.6-Watt + LiOn battery pack	24V 16-Watt + 110V transformer
SPEED	25 rpm	20/30/40 rpm	34 rpm
DB LEVEL	36-40 dB	<40 dB	<40 dB
MAX WEIGHT	16 lbs	10 lbs	10 lbs
BUILT-IN COMMUNICATION	RF	Forest Link RF/Bluetooth 	RF
AVG LIFECYCLE PER CHARGE	6 Months - 1 up & 1 down	6 Months - 1 up & 1 down	n/a
CHARGING	6-8 hrs, charger included	6-8 hrs, charger included	n/a
APP CONTROL	Bond Bridge & Sidekick	Forest Link	Bond Bridge & Sidekick
WARRANTY	3 years	5 years on motor, 2 on battery	5 years



FOREST
CRAFTED HARDWARE



SMART HOME
READY



APP
CONTROL



WIRELESS
REMOTE

62901 AC

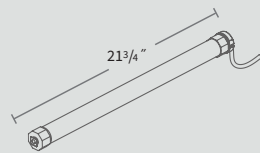

USE WITH

ENDEAVOR	-
RBS®	-
BCS	✓

SPECIFICATIONS

TORQUE	6.0 Nm
POWER	110V 113-Watt
SPEED	33 rpm
DB LEVEL	<40 dB
MAX WEIGHT	45 lbs
BUILT-IN COMMUNICATION	RF
AVG LIFECYCLE PER CHARGE	n/a
CHARGING	n/a
APP CONTROL	Bond Bridge & Sidekick
WARRANTY	10 years

OUR WIDE VARIETY OF CONTROL OPTIONS

Make finding a fit for your windows easy – controlling your roman shades by remote, wall switch, voice, app or even by home automation system.



EASYTOUCH CONTROLS

We have designed a new line of controls with a modern look and feel. Range of controls is up to 98’.

- The EasyTouch remote controls up to 6 systems, with the option to deactivate unused channels.
- EasyTouch wall switch is a sleek 2-channel option for your wall.



VOICE & APP CONTROL

Use Forest Link technology (WiFi) or the Bond Bridge Pro (RF) to integrate your window treatments into the Forest Connect App, Google Home, Alexa, and Siri, as well as automation systems like Crestron, Control 4, Elan, and more.



SIDEKICK GEN 4 REMOTE

5- or 1-channel remote control. Pairs directly with tubular motor. Use with Bond Bridge Pro or without. Estimated 10-year battery life.

Forest specializes in the development, production and supply of highly innovative drapery tracks and window coverings. We offer track solutions catering to the hospitality industry. Whether you choose our motorized tracks or rods, shades or hand drawn rods your client will experience comfortable luxury and optimal ease of use.

THE WORLD BEHIND YOUR DRAPERIES

More than thirty years ago it started with a flexible aluminum system, known as the Forest KS® system. The product line was expanded at a rapid pace, always focusing on functionality and quality. The technologies conquered the world. Hotels across the globe are satisfied users of Forest systems including iconic hotels like the Venetian, Hardrock and the mega hotels in Dubai.

Forest Group B.V. sells its products in more than 100 countries worldwide and has sales offices in The Netherlands, the United States, China, United Arab Emirates, United Kingdom and Poland, ensuring global availability.

Some well-known and recognized features of the Forest track systems are:

- **High-quality standards:** We guarantee a long lifespan.
- **Comfort and quiet:** Drapes open and close silently, creating a serene and comfortable environment.
- **Adds style to windows:** Always perfectly hanging drapery thanks to our systems, including motorized solutions.
- **Smart integration:** Controllable via app, voice, and home automation systems for ultimate convenience.
- **Sustainability:** We use a minimum of 75% recycled aluminum in our tracks.
- **Unique warranty:** 10-year warranty.



Drapery engineering by Forest