

## RMS RECESS MOTORIZED



SMART HOME  
READY



APP  
CONTROL



WIRELESS  
REMOTE



TOUCH  
CONTROL

RMS drapery track combines silent operation with the unique feature of recess mounting providing a stunning, clean look for your window covering design. This collection works effortlessly with all Forest Shuttle® motors, offering extensive control possibilities.

*RMS RECESS MOTORIZED TRACK  
FOREST SHUTTLE® HD MOTOR  
FOREST SHUTTLE® ECO MOTOR  
FOREST SHUTTLE® ION MOTOR*

THE WORLD  
BEHIND  
YOUR  
DRAPERIES





## RMS RECESS MOTORIZED SYSTEM

- Heavy duty aluminum extrusion, white, powder coated and lubricated with a patented process. Ultra-quiet and smooth operation for contract or residential applications.
- Maximum weight is 8 lbs/ft.
- Motorize with any Forest Shuttle. All Forest Shuttle motors include a 10-year warranty, the only one on the market.
- Control drapes with a gentle tug, wall switch remote, any home automation system or by smart phone app.





### ASSEMBLED SYSTEM



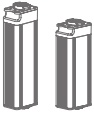
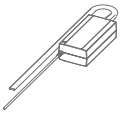
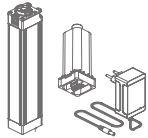

Includes track, masters, pinchpleat or ripplefold carriers, recess profile, fixing strip, wedge, motor, pulley, cover plate, and power supply plus choice of EasyTouch remote or wall switch.

**RMS RECESS FINISH** XX = finish color





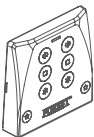





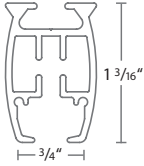
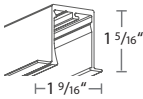

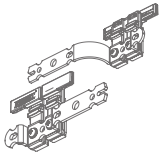
25  
White

RMS	COMPONENT
• 	<b>52925-25</b> Shuttle HD (M) white <b>52925-59</b> Shuttle HD (M) black <b>52939-25</b> Shuttle Eco (S) white
• 	<b>52934-25</b> Shuttle HD & Eco Power Cord 24 volt power supply with 16' cord
• 	<b>52926-25</b> Shuttle iOn white Includes battery charger below.
• 	<b>52924-59</b> Shuttle iOn Battery Charger Additional charger for Shuttle iOn motor
• 	<b>52949-25</b> Shuttle iOn Battery Pack Additional battery pack for Shuttle iOn motor
• 	<b>52948-25</b> Wi-Fi Dongle - Order 1/motor For voice & app control over wi-fi. Provides bi-directional feedback. Use with Shuttles HD and Eco, not iOn.

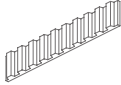
RMS	COMPONENT
• 	<b>52960-25</b> white <b>52960-59</b> black EasyTouch Remote 6 channel hand held remote Optional holder below can be ordered separately
• 	<b>52961-00</b> EasyTouch Remote Holder Optional and must be ordered separately
• 	<b>52933-25</b> white <b>52933-59</b> black EasyTouch Wall Switch 2 channel
• 	<b>52955-25</b> Bond Bridge Pro For voice and app control over RF. Easily pair using the Forest remote. Controls all of your devices in one hub.
• 	<b>52954-25</b> Sidekick Remote Works with or without Bond Bridge Pro, 1-5 channels.

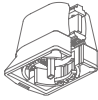
# RECESS MOTORIZED

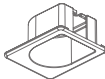
RMS	COMPONENT
• 	<p><b>51623-25</b> RMS Track white 23' x 10 tracks/bundle bundle = 230'</p>
• 	<p><b>51723-25</b> Recess Profile, 23' Order same length as track</p>
• 	<p><b>51724-25</b> Recess Profile Fixing Strip, 23' Order 6" shorter than track</p>
• 	<p><b>53914-25</b> Recess Profile Wedge Order 1 per track</p>
• 	<p><b>53908-25</b> Overlap Right <b>53909-25</b> Underlap Left FMS Plus Master Carrier</p>
• 	<p><b>52008-25</b> Slim Line Klick Carrier Draperies hang to conceal track</p>
• 	<p><b>52009-25</b> Ball Bearing Carrier for motorization</p>
• 	<p>Two Piece Connected Snap Carrier w/ Square Base, in plastic sleeve. Use 1 1/4" snap tape <b>2114-25</b> 60% fullness, 2 5/8" OC <b>2111-25</b> 80% fullness, 2 3/8" OC <b>2112-25</b> 100% fullness, 2 1/8" OC <b>2115-25</b> 120% fullness, 1 7/8" OC</p>

RMS	COMPONENT
• 	<p><b>9112-25</b> Transport Belt</p>
• 	<p><b>52512-25</b> white Transport Belt Connector</p>
• 	<p><b>53903-25</b> Motor Pulley Connects motor to track</p>
• 	<p><b>53911-25</b> Upside Down Motor Pulley</p>
• 	<p><b>53910-25</b> Return Pulley</p>
• 	<p><b>53912-25</b> Cover Plate for Recess Motor and Return Pulley</p>
• 	<p><b>53913-25</b> Cover Plate for Recess Motor, Upside Down Motor, and Return Pulley</p>

# SHUTTLE MOTOR SPECIFICATIONS



## SHUTTLE® HD (M)

## SHUTTLE® ECO (S)



### SPECIFICATIONS

VOLTAGE SHUTTLE	24V DC	24V DC
RECEIVER	Internal, optional	Internal
POWER SUPPLY	External, 100-240V AC - 1.5A, 50-60Hz; Output 24V DC - 2.7A	External, 100-240V AC - 0.8A, 50-60Hz; Output 24V DC - 2.5A
MAX POWER	65W	40W
TORQUE	1.5 Nm	1.0 Nm
TRAVEL SPEED	5.5" per second standard 7" per second maximum	5.5" per second standard 7" per second maximum
NOISE LEVEL	< 40 dB(A)	< 40 dB(A)
MAXIMUM WEIGHT	160 lbs per motor 120 lbs per motor - curved track	100 lbs per motor 90 lbs per motor - curved track
DIMENSIONS	2.76" x 1.97" x 9.5"	2.76" x 1.97" x 7.5"
CERTIFICATIONS/MARKINGS	CE/FCC/DOE	CE/FCC/DOE
COLOR OPTIONS	White / Black	White

### FEATURES

TOUCH CONTROL TECHNOLOGY	√	√
INTEGRATED EMERGENCY CONTROL	√	√
RF COMMUNICATION STANDARD	√	√
Z-WAVE COMMUNICATION	-	-
AUTOMATION SYSTEM COMPATIBLE	√ using RS485 & dry contacts	√ using RS485 & dry contacts
WI-FI COMPATIBLE	√	√
WORKS WITH WIFI DONGLE	√	√
CAN BE USED WITH CURVED TRACK	√	√
PLUG & PLAY	√	√
WARRANTY	10 Years	10 Years

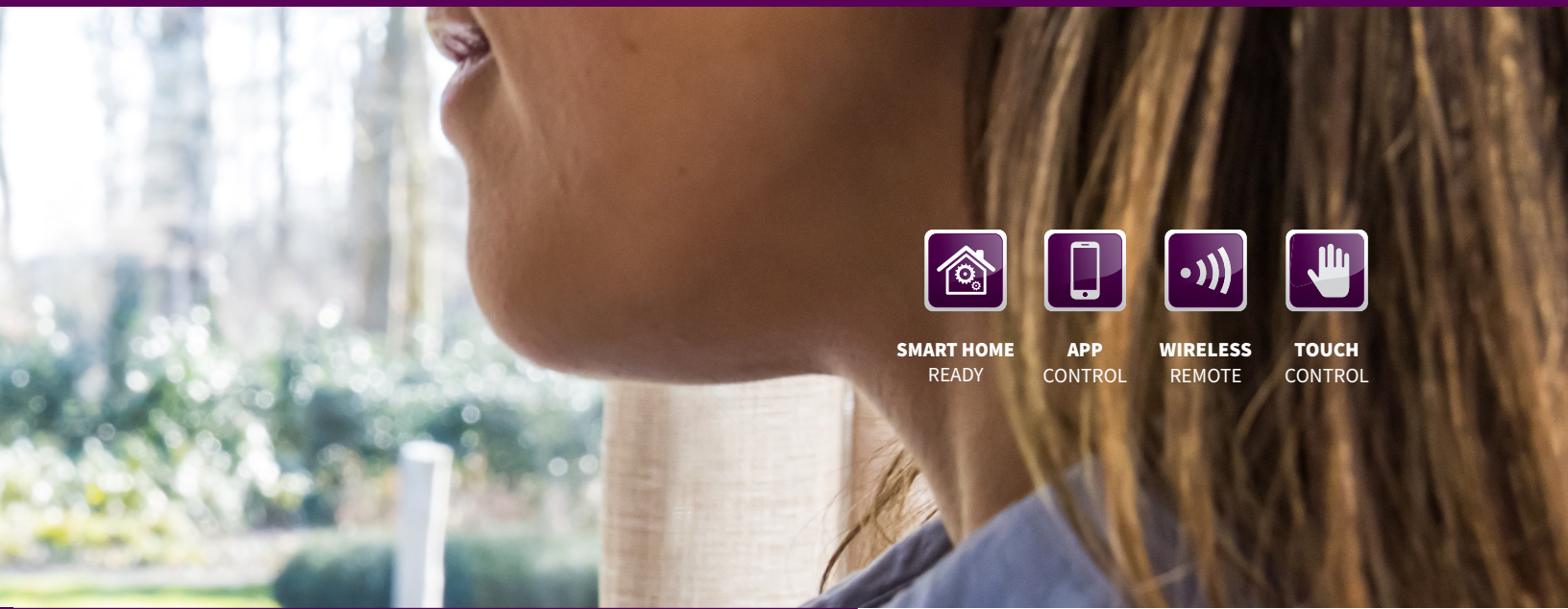

**SMART HOME**  
READY



**APP**  
CONTROL



**WIRELESS**  
REMOTE



**TOUCH**  
CONTROL

## SHUTTLE<sup>®</sup> iOn



VOLTAGE SHUTTLE	14.8V DC
RECEIVER	Internal
BATTERY	Lithium iOn battery + charger (3-4 months between charges)
MAX POWER	30W
TORQUE	1.0 Nm
TRAVEL SPEED	5.5" per second standard
NOISE LEVEL	< 40 dB(A)
MAXIMUM WEIGHT	55 lbs per motor 40 lbs per motor - curved track
DIMENSIONS	2" x 3" x 12.25"
CERTIFICATIONS/MARKINGS	CE/FCC/DOE
COLOR OPTIONS	White

## SPECIFICATIONS

TOUCH CONTROL TECHNOLOGY	✓
INTEGRATED EMERGENCY CONTROL	✓
RF COMMUNICATION STANDARD	✓
Z-WAVE COMMUNICATION	-
AUTOMATION SYSTEM COMPATIBLE	✓ using RS485 & dry contacts
WI-FI COMPATIBLE	✓
WORKS WITH WI-FI DONGLE	-
CAN BE USED WITH CURVED TRACK	✓
PLUG & PLAY	✓
WARRANTY	10 Years on motor 2 years on battery pack

## FEATURES

Our wide variety of control options make finding a fit for your windows easy – controlling the drapes by hand, wall switch, remote or even by home automation system.



### TOUCH CONTROL

Open or close your drapes with a gentle tug.



### FOREST CONTROLS

We have designed a new line of controls with a modern look and feel. Range of controls is up to 98'.

- The EasyTouch remote controls up to 6 systems, with the option to deactivate unused channels.
- EasyTouch wall switch is a sleek 2-channel option for your wall.



### BOND BRIDGE PRO

With the Bond Bridge Pro, easily pair your Forest remote and get app control for Forest motorized window coverings and other devices all in one place.



### SIDEKICK REMOTE

5- or 1-channel remote control. Pairs directly with drapery motor. Use with Bond Bridge Pro or without. Estimated 10-year battery life.

**FOR ADDITIONAL CONTROL OPTIONS, SEE THE ROADMAP ON THE FOLLOWING PAGES.**

# MOTORIZATION CONTROLS ROADMAP



## Wall Switch & Remote

Without feedback

RF

### Compatible Shuttle Motors

S  M  iOn

### Compatible Controls

- Easy Touch Wall Switch
- Easy Touch Remote
- Sidekick Remote



## Voice and App Control local and remote

With feedback

WiFi

Connect using Forest WiFi Dongle



### Integrations

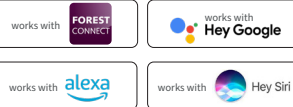

Integrations when cloud services are present



### Compatible Shuttle Motors

S  M  iOn

### Compatible Controls w/ Dongle

- Easy Touch Wall Switch
- Easy Touch Remote
- Sidekick Remote

Without feedback

RF

Connect using Bond Bridge Pro



### Integrations



### Voice Assistants

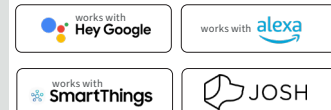

And others

### Compatible Shuttle Motors

S  M  iOn

### Compatible Controls

- Easy Touch Wall Switch
- Easy Touch Remote
- Sidekick Remote



**Wired Automation System**  
we advise you work with  
an installation specialist

With feedback

Without feedback

RS485

Dry Contact

Integrations

Control4

CRESTRON

SAVANT

RCI

and others

Integrations

Control4

CRESTRON

SAVANT

LUTRON

and others

**Compatible Shuttle Motors**

S  M  iOn

**Compatible Controls**

Easy Touch Wall Switch

Easy Touch Remote

Sidekick Remote

**Compatible Shuttle Motors**

S  M  iOn

**Compatible Controls**

Easy Touch Wall Switch

Easy Touch Remote

Sidekick Remote



Forest specializes in the development, production and supply of highly innovative drapery tracks and window coverings. We offer track solutions catering to the hospitality industry. Whether you choose our motorized tracks or rods, shades or hand drawn rods your client will experience comfortable luxury and optimal ease of use.

## THE WORLD BEHIND YOUR DRAPERIES

More than thirty years ago it started with a flexible aluminum system, known as the Forest KS® system. The product line was expanded at a rapid pace, always focusing on functionality and quality. The technologies conquered the world. Hotels across the globe are satisfied users of Forest systems including iconic hotels like the Venetian, Hardrock and the mega hotels in Dubai.

Forest Group B.V. sells its products in more than 100 countries worldwide and has sales offices in The Netherlands, the United States, China, United Arab Emirates, United Kingdom and Poland, ensuring global availability.

### Some well-known and recognized features of the Forest track systems are:

- **High-quality standards:** We guarantee a long lifespan.
- **Comfort and quiet:** Drapes open and close silently, creating a serene and comfortable environment.
- **Adds style to windows:** Always perfectly hanging drapery thanks to our systems, including motorized solutions.
- **Smart integration:** Controllable via app, voice, and home automation systems for ultimate convenience.
- **Sustainability:** We use a minimum of 75% recycled aluminum in our tracks.
- **Unique warranty:** 10-year warranty.



*Drapery engineering by Forest*